

METASYS

- D** Amalgamabscheider
MULTI SYSTEM TYP 1
Einbau, Betrieb und Wartung

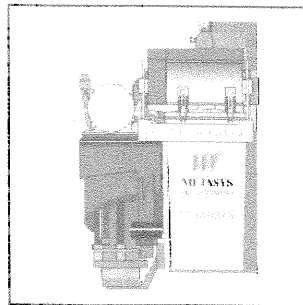

- GB** Amalgam Separator
MULTI SYSTEM TYPE 1
Assembly, operation and maintenance

- F** Récupérateur d'amalgame
MULTI SYSTEM TYP 1
Installation, fonctionnement et entretien

- I** Separatore d'amalgama
MULTI SYSTEM TYP 1
Montaggio, funzionamento e manutenzione

- E** Recuperador de amalgama
MULTI SYSTEM TYP 1
Montaje, servicio y mantenimiento

Contents, Key to symbols

The footnote found on each page defines the user group for which that particular information is aimed.

1. Contents:

	Seite
1. Contents	2
2. Key to symbols	2
3. General information	3
4. Application	4
5. Construction	4
6. Key to type plates	4
7. Technical Data	5
8. Method of operation	5
9. Methods of installation	6
10. Assembly	7
11. Hose Connections	8
12. Electrical Connections	8
13. Key to External Displays	9
14. Key to Internal Displays	9
15. Changing the Collection Container	10
16. Disposal of Used Container	11
17. Maintenance, Cleaning and Disinfection	12
18. The Annual Inspection	13
19. The 5 Yearly Inspection	14
20. Routine Inspection	15

2. Key to symbols:



Warning that to ignore the following instructions could lead to personal injury, disrupt operation or damage the apparatus.



Important notice, the information to which the user should pay particular attention.

General Information

3. General Information:



METASYS can only guarantee safety, reliability and performance of the apparatus when:

- ☐ Installation, changes or repairs are carried out by authorised service personnel in compliance with Standard IEC 601-1 Part 1: general rules for safety.
- ☐ The electrical installation complies with IEC regulations.
- ☐ The apparatus is assembled, operated and maintained according to the instructions provided.
- ☐ Only original parts are used for repairs or replacements
- ☐ All the guidelines provided by the manufacturer on the correct use of the Amalgam Separator MST1 are followed.



following the commissioning of the Amalgam Separator MST1 the installation report, contained within the apparatus documents, must be filled in and sent to METASYS to confirm the time period of the guarantee.

- ☐ Every inspection, service intervention and exchange of collection container should be recorded in the apparatus Logbook.
- ☐ By law, every amalgam waste disposal certificate should be retained.
- ☐ When requested by an authorised engineer, METASYS agree to make all documentation available for the use of technically qualified service personnel.
- ☐ METASYS accept no responsibility for damages caused outside their influence such as poor installation, improper use of the apparatus or unauthorised technical intervention.
- ☐ When the complete Amalgam Separator has been deassembled at the end of its working life, it must be returned to the manufacturer for disposal.

Application, Construction, Key to Type Plates

4. Application:

The METASYS MULTI SYSTEM TYPE 1 (MST 1) is a two step individual amalgam separator with integrated air/water separation and unit selection valve.

5. Construction:

The amalgam separator MST 1 is constructed out of 3 modules:

1 Modul 1 is the central component housing all the air, water and Electrical connections as well as the motherboard, diagnostics board and filter unit.

2 Modul 2 is the separating element of the apparatus where the sedimentation stages take place. Module 2 also contains the collection container and unit selection valve.

3 Modul 3 is the centrifuge and therefore the dynamic section of the amalgam separator.

6. Key to Type Plates:

4 see diagram

The Type Plates can be found on Module 1 and are visible when Module 2 is removed. (turn the yellow locking bolts upwards and pull Module 2 forwards out of the housing).

- 4.1** Equipment type
- 4.2** Mains supply data
- 4.3** German Institute for Construction Technology registration number
- 4.4** Serial number
- 4.5** Address of manufacturer
- 4.6** CE conformance symbol
- 4.7** VDE inspection symbol
- 4.8** Type BF symbol
- 4.9** Protection class 2
- 4.10** Compliance, as per ÜZVO

Technical Data, Method of Operation

7. Technical Data

Power supply	24 V AC
Frequency	50/60 Hz
Max. current consumption	2A
Max. power loading	46VA
Low pressure range	50 - 250 mbar
Separation rate	>95 %
Collection container volume	300 cm ³
Max. ambient temperature	40 °C
Possible suction systems	wet or dry low pressure systems
Max. water flow rate	3 l/min through basin 1.5 l/min through suction line
5 see diagram	
Total dimensions: (h x b x d)	305 x 210 x 104 mm

8. Method of Operation:

6 See diagram

By lifting the suction hose, the unit selection valve is opened **6.1** and the suction power is fed into Module 2. Once there, using the "cyclone principle", the air and water are separated **6.2**. The dry air leaves the system through the unit selection valve to the suction motor **6.3**.

The remaining fluid and debris is forced through into the collection container **6.4** where the first step of the amalgam separation takes place. As the coarse particles in the collection chamber are sedimented the fluid level rises. As soon as the fluid level reaches the limit probes, the pump motor **6.5** is started for a selected time span.

The pump forces the pre-cleaned fluid into the centrifuge **6.6** where, once sufficiently full, the second step of the amalgam separation process takes place. Waste water from the rinsing basin **6.7** is directed into the centrifuge. During the rotation of the centrifuge the coarse particles are flung to the walls of the inner centrifuge chamber and the clean water is forced over the edge of the outer chamber wall where it is then fed into the drains **6.8**.

As soon as the fluid level drops below the level of the probes, electrical contact is broken. The centrifuge continues to rotate for a short time afterwards before coming to an abrupt stop. The further rotating water column rinses the debris off the walls of the centrifuge and into the bottom of the chamber **6.9**.

Following a short pause the pump motor again comes into operation, pumping the coarse particles, together with the remaining water, into the collection container.

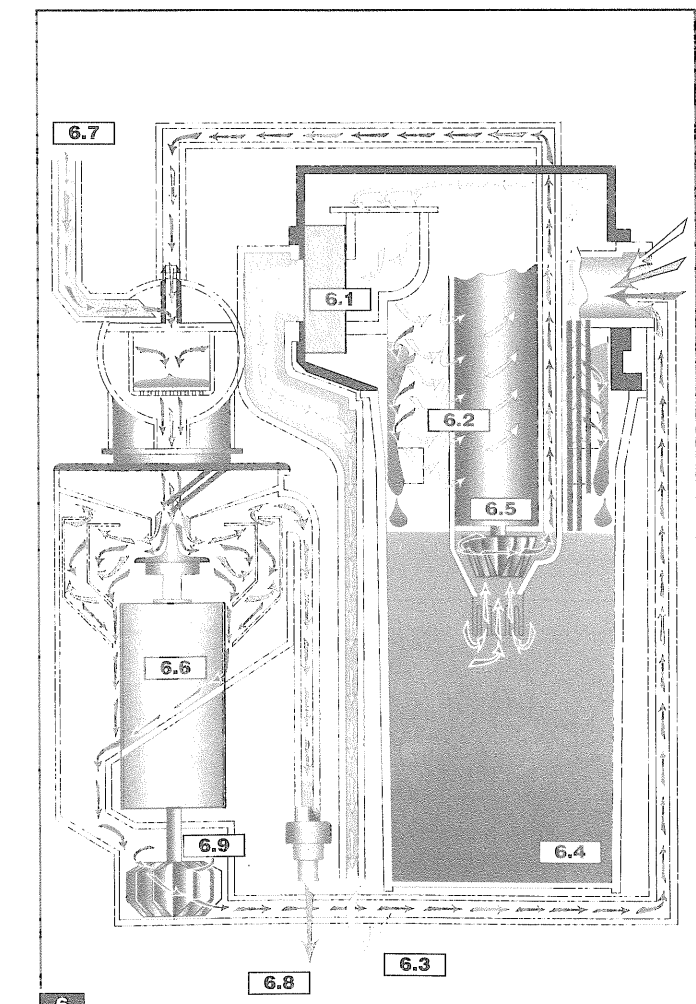
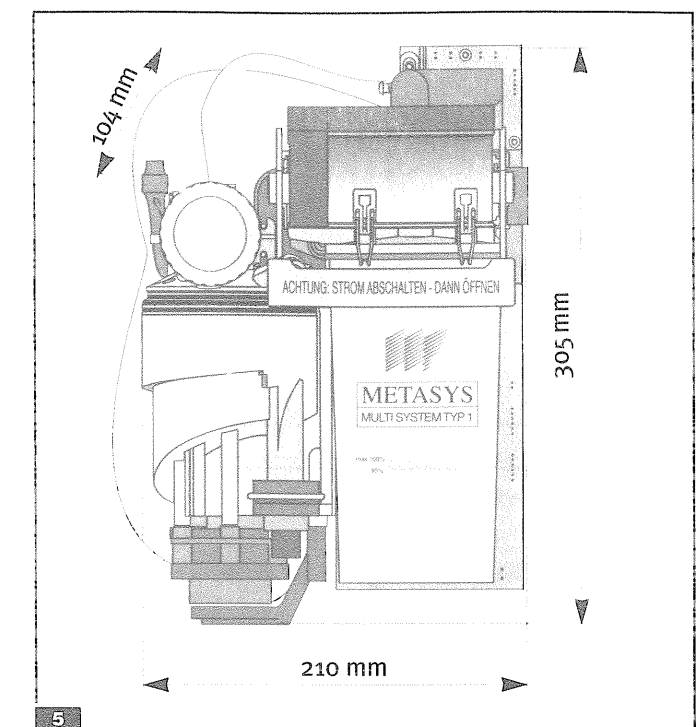
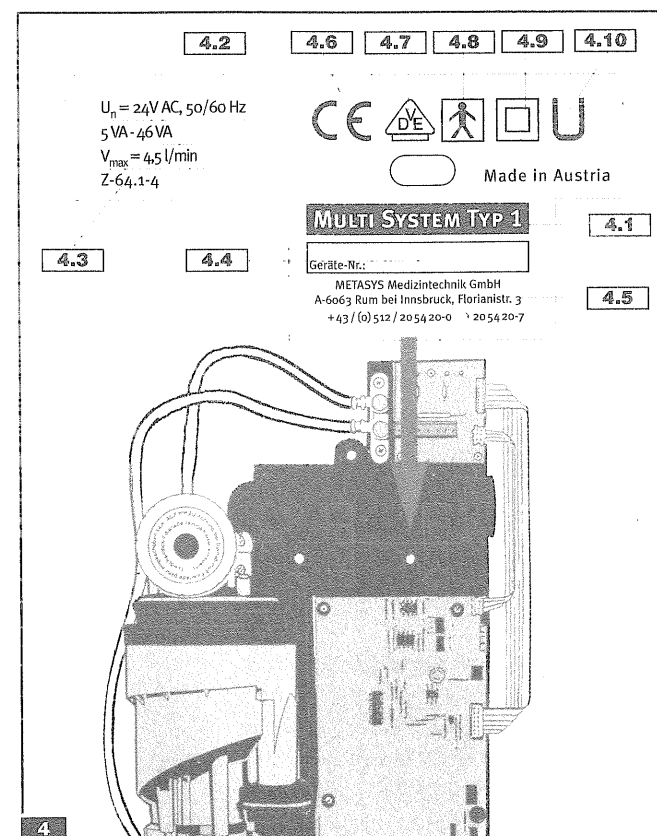
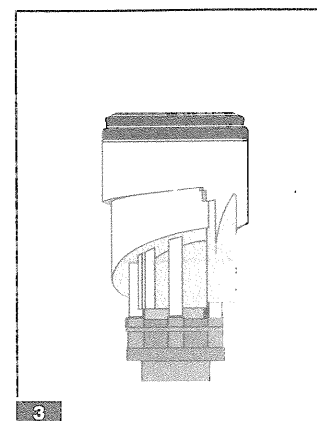
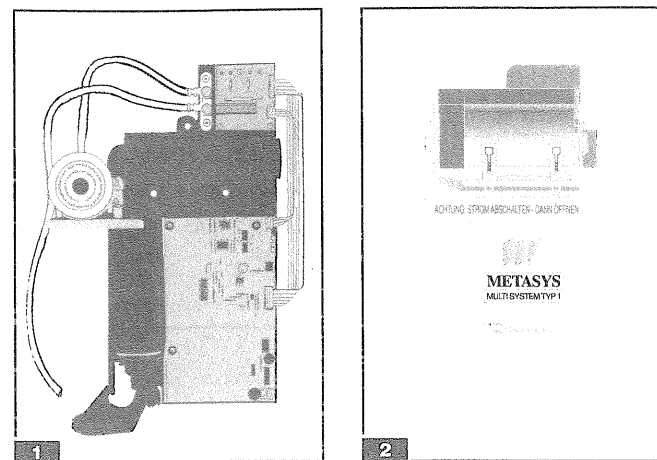

Methods of Installation

9. Methods of Installation:

Due to the modular construction of the MULTI SYSTEM TYPE 1 a choice of installation methods are available.

1 Integration with the rinsing basin:

The direct integration of the amalgam separator with the rinsing basin is the preferred method because this keeps the hose to the amalgam separator as short as possible, reducing the risk of early sedimentation.

The unit should be attached to the rinsing bowl in such a way as to keep vibration levels as low as possible.

2 Installation behind the head of the patient:

When no rinsing bowl is available in the treatment area, and the suction is installed behind the head of the patient, the MST 1 can be installed in the cabinet at the rear of the patient.

The connection for the rinsing bowl will in this case be sealed.

3 Installation within an independent housing:

Should it be impossible to integrate the amalgam separator with the existing equipment the MST 1 can be encased in its own aesthetic housing which requires only a minimum amount of floor space.

4 Split installation:

For a treatment area which has a rinsing bowl but also suction behind the patients head, the amalgam separator can be assembled in two parts.

Module 1 and Module 2 would be installed behind the head of the patient and Module 3, the centrifuge, would be encased in its own special housing and attached to the rinsing basin. Both parts are attached by underfloor cables to minimise vibration.

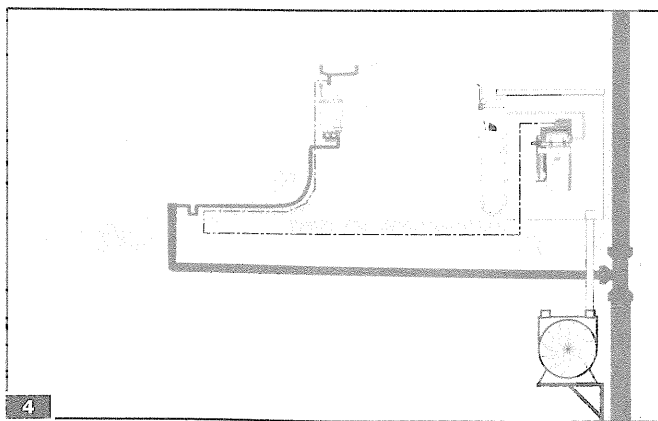
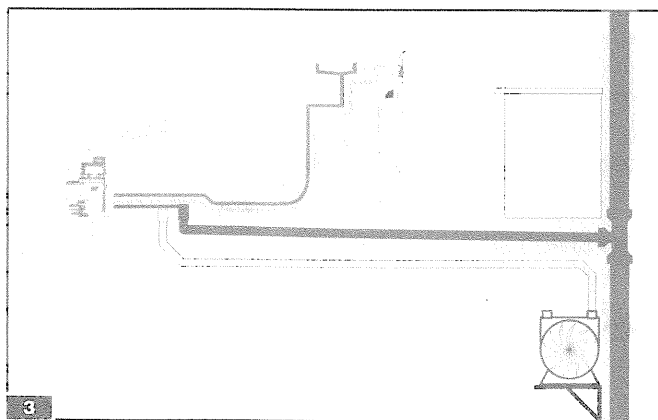
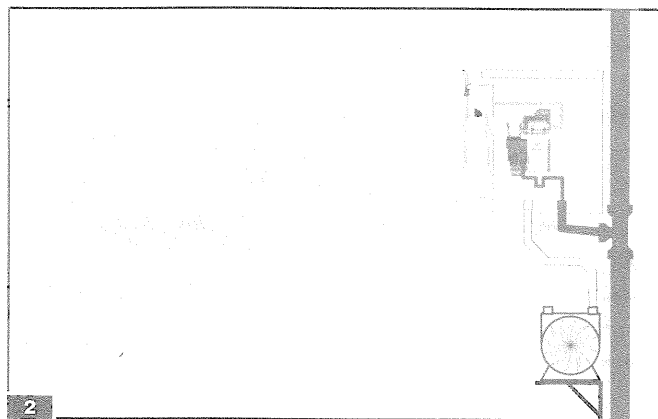
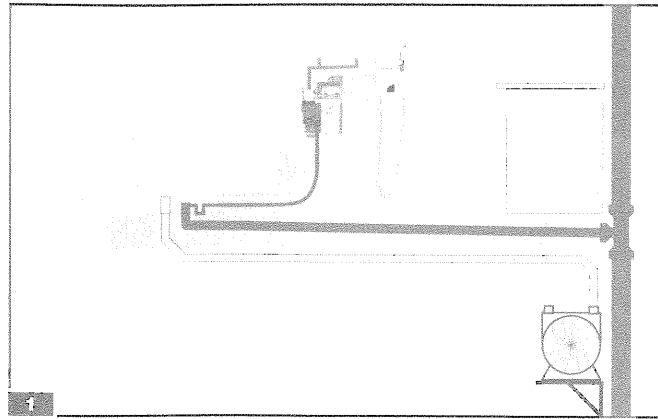

Assembly

10. Assembly:

5 Fitting:

The following space should be left for the apparatus:
H x W x D 350 x 250 x 120mm



To reduce vibration, the fitting of the device must only be through the 3 holes in the suspension via the appropriate damping insets to the supporting parts of the treatment unit.

The centrifuge of the amalgam separator must be able to swing free without contact to other housing parts of the unit.



The electrical earth plate (5.1) must be fitted behind Module 1!

6 Preliminary filter:



6.1 Should there be no hose support, a preliminary filter should be fitted with maximum 1 mm mesh to the suction side of the amalgam separator, in a place easily accessible for practice personnel.

6.2 The coarse filter fitted into the outlet of the rinsing basin may have a maximum 3mm mesh width and must not be removed when the amalgam separator is in operation.

7 Outlet hoses:



To prevent early sedimentation the hoses leading to the amalgam separator should be as short as possible.

Soiled dental hoses should be replaced during installation and should be disposed off through an appropriately authorised company.

The amalgam separator must be plumbed into the waste water drain. The waste water must be able to run freely so that the effectiveness of the separator is not affected by any build up of backwater.

The rinsing process of the rinsing basin should be limited by a timer or special button to a maximum of 30 seconds at a maximum water flow rate of 3 litres/min.

8 Main switch:



The amalgam separator should be switched off at least once a day. The connection to the 24 VAC must be in circuit with the practice main switch.

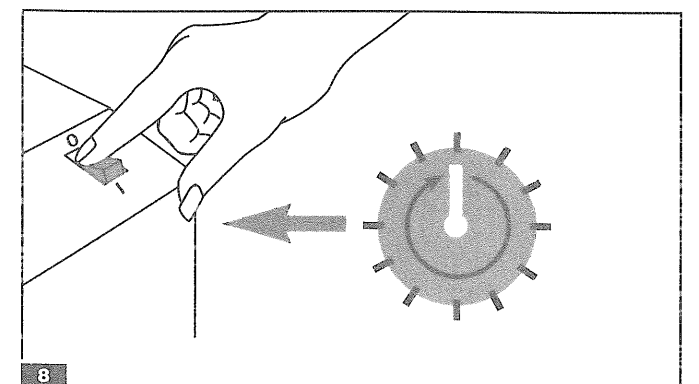
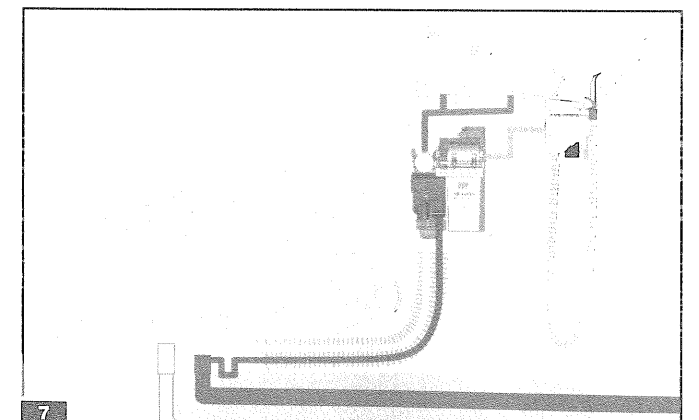
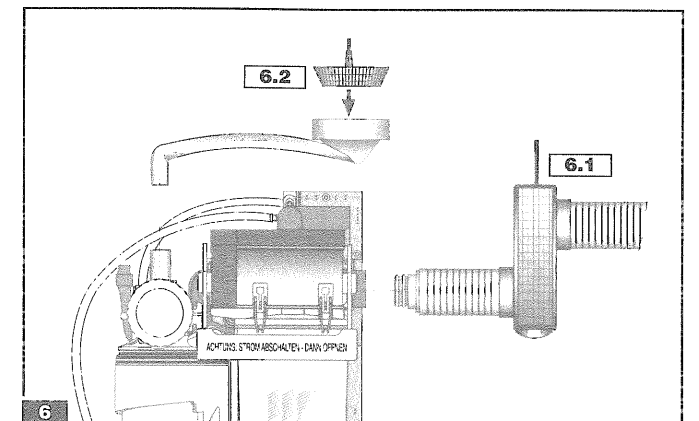
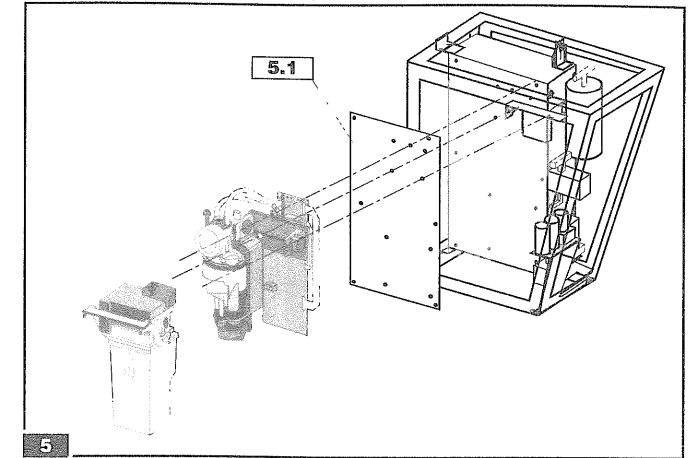

Hoses connections, Electrical connections

11. Hoses connections:

- 1** see diagram
 - 1.1** Connection to rinsing basin waste pipe
 - 1.2** Connection for suction hose
 - 1.3** Connection for vacuum hose (leading to suction motor)
 - 1.4** Connection to clean water drainage pipe
 - 1.5** Connection for overhead hose (eg, drinking glass filler)
- i** Hose adhesives, adapters and other spare parts necessary can be purchased from us.
- !** All unnecessary connections should be sealed.

12. Electrical connections:

- 2** see diagram
 - 2.1** Motherboard
 - 2.2** Diagnostics board
 - 2.3** Module 2
 - 2.4** Module 3
 - 2.5** External visual display
 - 2.6** Main switch and suction machine relay
- SV1: Socket for centrifuge probe
 SV2: Socket for centrifuge motor
 SV3: Socket for 24 VAC mains power supply
The mains supply must be drawn through a safety Transformer which complies with IEC 601-1 / VED 0750 Part 1 / DIN EN 60601-1 and IEC 60742 + A1 / DIN EN 60742.
 SV4: Socket for external visual display
 SV5: Connection to diagnostics board (power supply for motor and magnetic valve in Module 2)
 SV6: Connection to diagnostics board (probes in Module 2)
 SV7: Socket for support signal (12-24 VAC / DC)
 F1: Main fuse 3.15 AT
 F2: Fuse for pump motor in Module 2 (0.8 A)
- i** If you remove the links on J1, J2 and J3 you can reach a better reaction of the probes although the water conduction is lower.
- !** Fuses must only be replaced by the same type!

Key to external display, Key to internal visual display

13. Key to external display:

- 3** see diagram
- 3.1** Control light 1: „Ready for operation“
 Green illuminated LED confirming unit is switched on
- 3.2** Control light 2: „Centrifuge error“
 Red flashing: „error“
 Should the red light be flashing, switch the main button off and then following a short break switch on again. Repeat a few times. If the error signal remains please contact your service technician.
- 3.3** Control light 3: „Container full display“
 Yellow light illuminated, audible buzzer signal activated which can be switched off by pressing the „reset“ button. This warning tells you that the collection container is 95% full.

- The collection container should be changed. However it is possible to continue operation until the container is 100% full. As a reminder the yellow LED remains illuminated and every time the unit is switched on the buzzer signal is activated.
- !** Yellow light illuminated and audible buzzer signal which cannot be switched off by pressing „reset“. This warning tells you the collection container is 100% full.
 - i** The collection container must be changed immediately as power to the unit will be automatically terminated making further operation impossible.

- 3.4** Alarm- RESET- button
 By pressing the red reset button the audible 95% full buzzer warning can be switched off.

14. Key to internal visual display:

- 4** Provides information about the condition of the apparatus.
- 4.1** LED 1: support signal
 Suction hose is free and there is a 12-24 VAC/DC power supply through socket SV7.
- 4.2** LED 2: magnetic valve
 The magnetic valve is operational and the emergency stop probe has not been activated.
- 4.3** LED 3: pump, Module 2
 The pump is operational.
- 4.4** LED 4: centrifuge probe
 The centrifuge probe is connected.

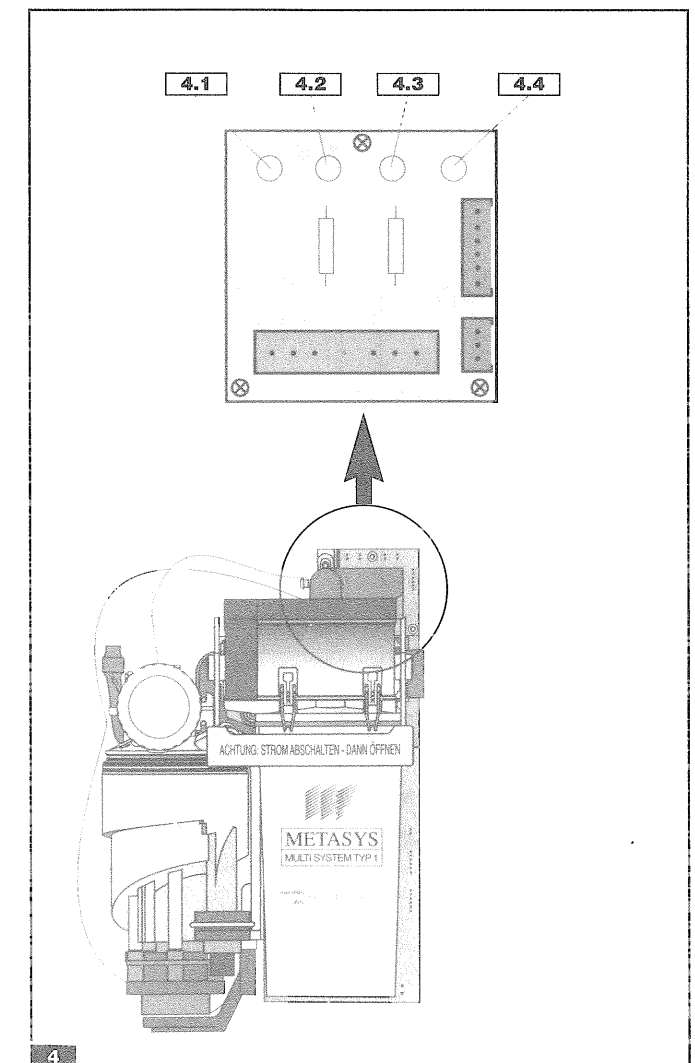
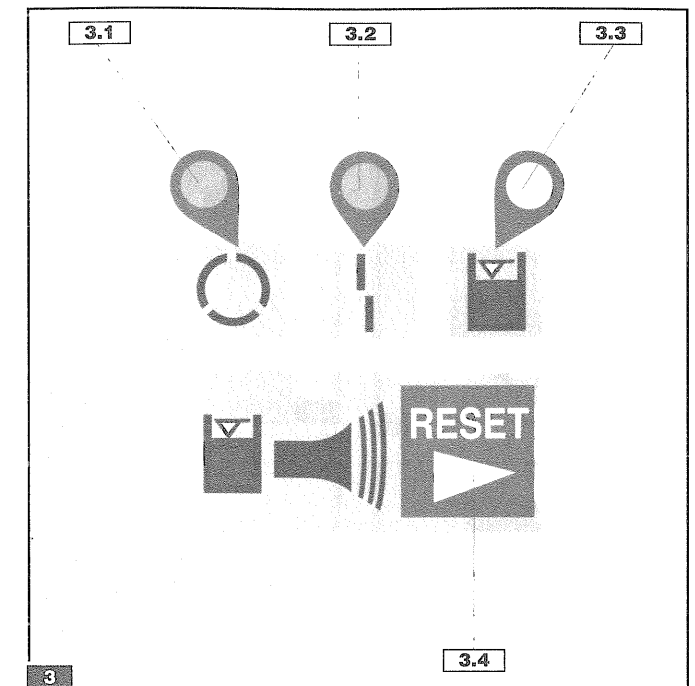
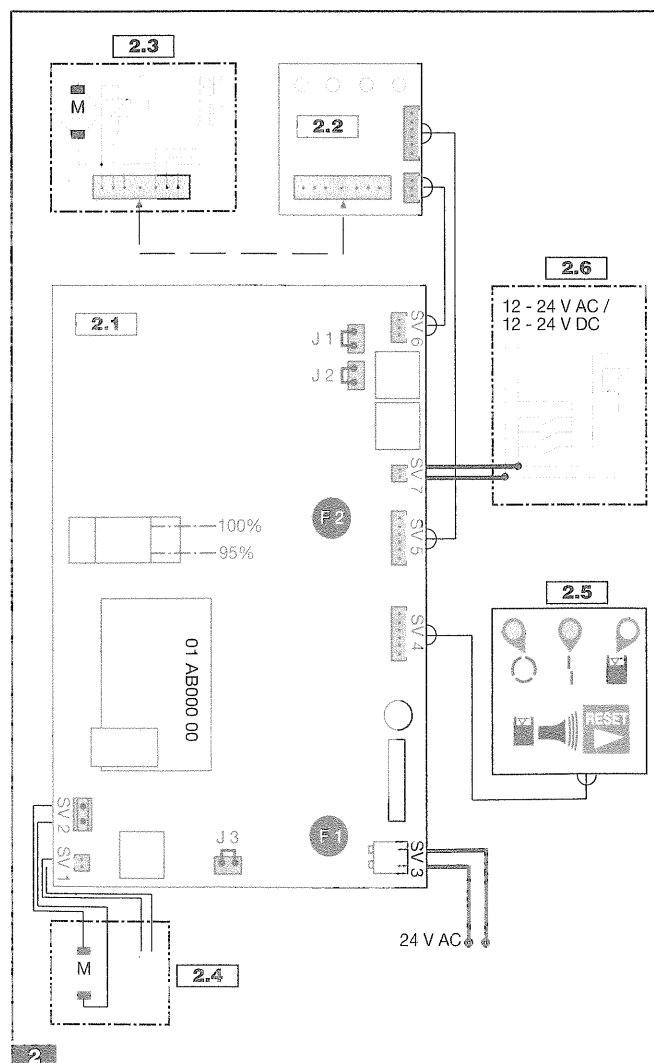
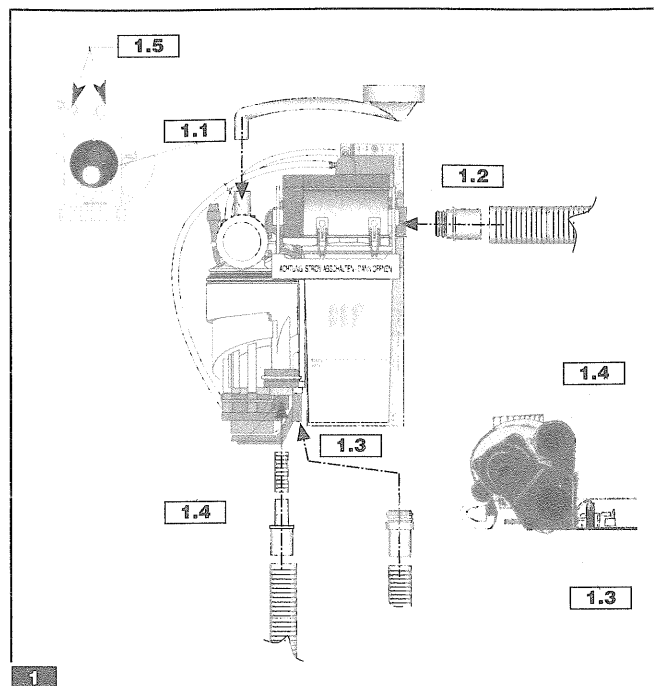

Changing the collection container

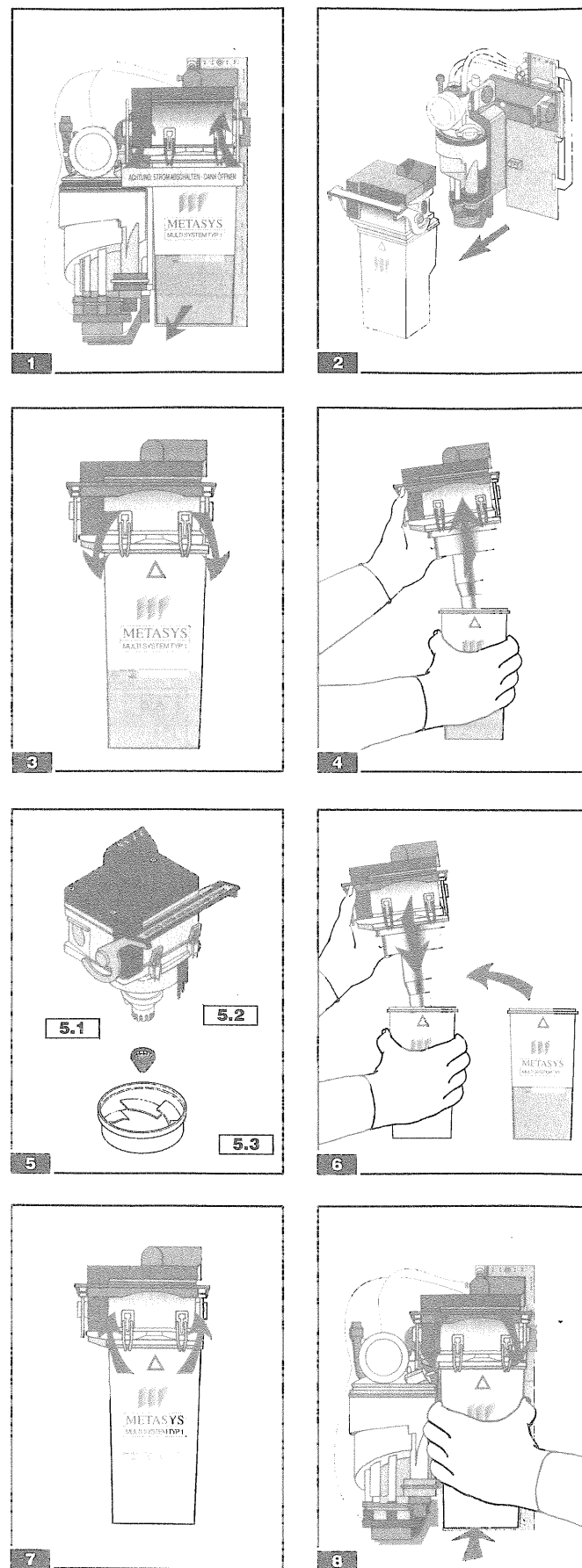

15. Changing the collection container:

**Switch off the main button of the unit !
Wear protective gloves !**

- Prepare a new collection container and take out the enclosed disinfectant bag !**
- Remove the lid of the treatment unit.**

- 1** Turn the locking bracket upwards.
 - 2** Remove Module 2 by pulling it forwards out of the unit and place it on a level, non-slip surface.
 - 3** Open the four yellow clips on Module 2.
 - 4** Holding the collection container firmly, pull off the top.
 - 5** If the pump filter **5.1** is soiled remove it over a drip tray, clean it and replace it onto the end of the suction end of the pump housing.
The probes **5.2** in Module 2 can be cleaned with a soft cloth.
The air brakes **5.3** can also be removed for careful cleaning.
- Use the positioning markings when reassembling the apparatus. (arrow on the air brakes to the notch on Module 2)**

- 6** Place the cleaned and correctly assembled Module 2 onto a new collection container.

paying attention to the blue marking on the FRONT of the container.

- 7** Close the four yellow clips on Module 2.
- Clean the seal on the supporting element with a soft cloth and grease with vaseline.**

- 8** Carefully insert the amalgam separator into its support and close the locking bracket.

- Switch on the main button.**

The amalgam separator will start running for a short time following, by the external visual display which will signal that it is ready for operation. (Signal 1, illuminated green)

Disposal of full collection container

16. Disposal of full collection container:

**Wear protective gloves and face mask!
Contact with the contents of the container should be avoided!**

For technical and hygienic grounds the collection container is designed for single use.

The reuse of a soiled container can lead to technical problems and will invalidate the apparatus guarantee!

The full container should be returned to a suitably authorised company (eg METASYS) for disposal.

By law, a confirmation of disposal certificate should be given and retained.

The simplest method of disposal is by using the ECO-TRANSFORM.

9 see diagram:

Cut one end of the disinfectant bag which is found enclosed with the new container and empty it into the full container for final disinfection.

10 see diagram:

Using firm pressure, close the full container using the green lid which is also provided with the new container.

11 see diagram:

Check that the eight safety catches on the lid are secured.

12 see diagram:

Perform a leak test by holding the closed container upside down a drip pan to check the lid is fully closed.

13 see diagram:

Place the secure collection container into the two half Styropor shells of the transport carton.

14 see diagram:

Close the transport carton according to the enclosed handling instructions.

15 see diagram:

Place the appropriate return label provided onto the transport carton and return it for lawful disposal to an authorised company (ie. METASYS).

16 see diagram:

Empty any amalgam residue from the preliminary filters into a special receptacle (eg. METASYS ECO CENTRE) and again ensure correct disposal (eg. Through METASYS TRANSFORM).

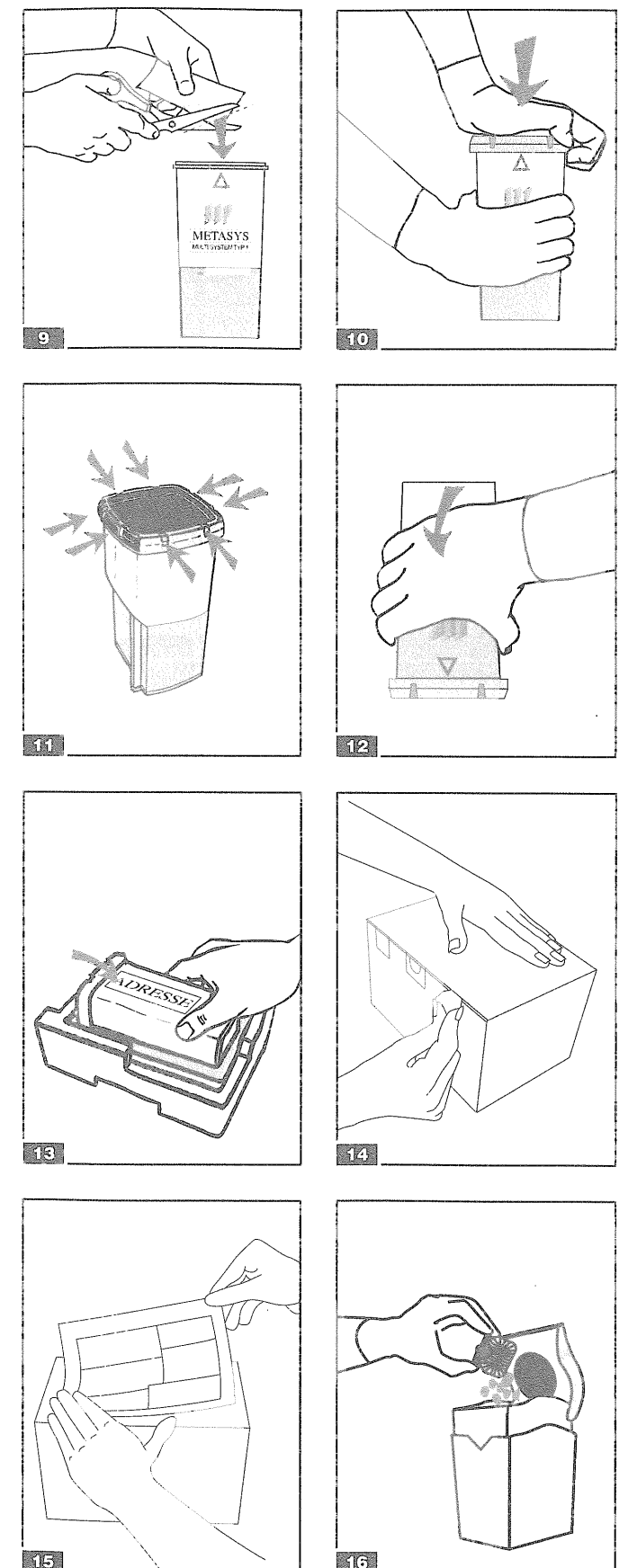

Maintenance, cleaning and disinfection

17. Maintenance, cleaning and disinfection:

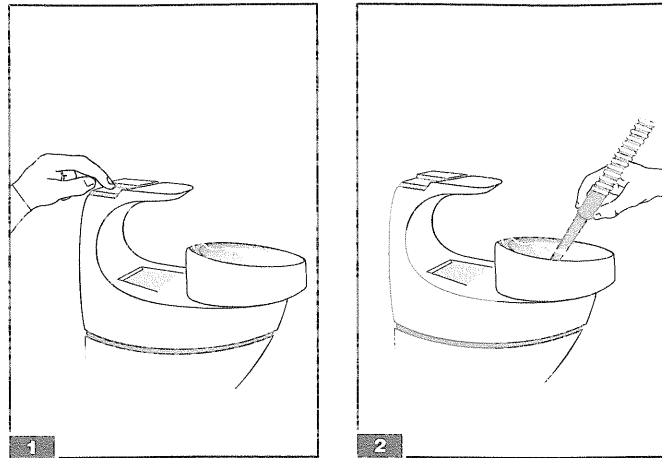

1 see diagram :

Following every treatment the rinsing basin should be rinsed through.

2 see diagram :

After each treatment the basin should also be switched on to suck off some water.

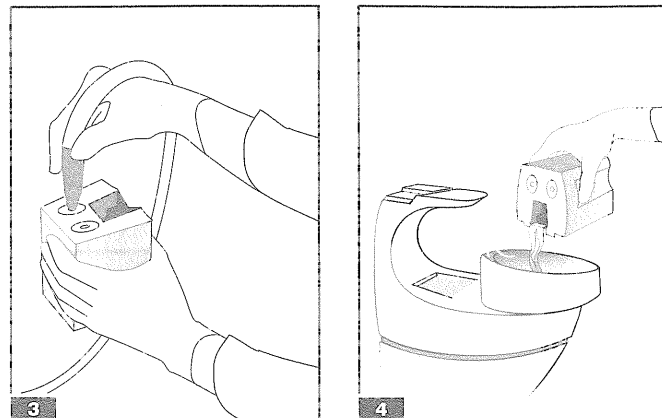

3 see diagram :

Twice daily, after the water has been drained off, a specifically designed disinfectant should be used. This should be done before long periods of disuse such as before the lunch hour, after work and also before holidays.

We recommend the use of METASYS GREEN & CLEAN M2

4 see diagram :

The rinsing basin should also be rinsed with an amalgam separator specified disinfectant twice daily.

5 see diagram :

At least once a week, and in cases of heavy use daily, the filter box should be emptied and cleaned.

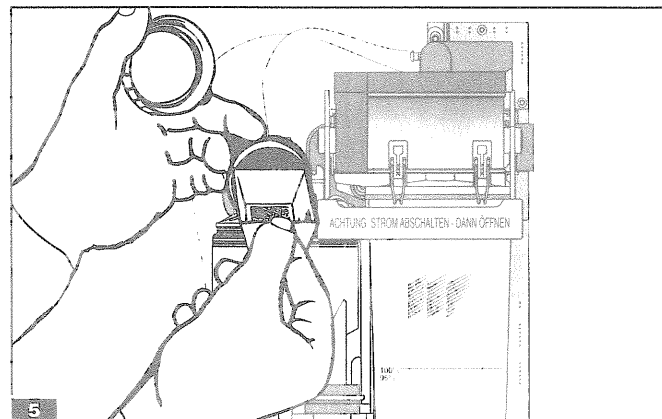

5 see diagram :

The amalgam residue which is emptied from the filter box should be collected in a suitable container (eg METASYS ECO CENTRE) and sent for authorised disposal.

6 see diagram :

As required, remove and clean the centrifuge probes.

⚠ When the centrifuge is operational yet no longer running automatically, it is probable that the probe is dirty and has shorted!

- Switch off at the main switch.
- Remove Module 2
- Remove the probe from the filter housing.
- Clean the probe and probe opening.
- Grease the probe seal with vaseline.
- Push the probe back into the filter housing until an audible click is heard.
- Replace Module 2.
- Switch main button back on.

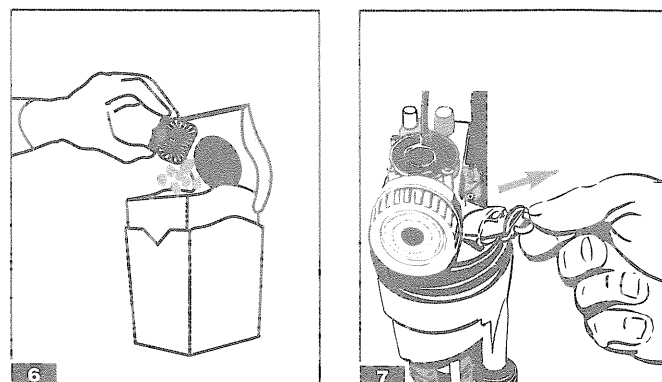

The annual inspection

18. The annual inspection:



According to the German Institute of Construction Technology requirements, the display elements of amalgam separators have to be tested at least once a year by an authorised technician.

To simplify the following procedure we recommend the use of our test kit (part number 40 40 0002)

8 + 9 Testing of Signal 1 „Ready for Operation“:

- Switch main button off and then on again.
- The green light should be illuminated.
- The centrifuge should run twice for a short period before stopping abruptly.

10 Testing of Signal 2 „Centrifuge error“:

- Switch off the main button
- Remove Module 2
- Disconnect the centrifuge plug SV2 from the motherboard ①
- Short out the SV2 socket on the motherboard ②
- With the SV2 connection shorted out, switch on the main switch ③
- Signal 2 should be flashing red.
- By requirements of Module 2 suction should now not be possible.
- Switch off at the main switch.
- Connect the centrifuge plug SV2 back into the motherboard socket.
- Replace Module 2.

11 Testing of Signal 2 „Container full display“

- Switch off at main button
- Remove Module 2
- Disconnect the Centrifuge plug SV2 from the motherboard. ①
- Uncover the lower diode on the motherboard ②
- Switch on the main switch. ③
- Signal 3 should be illuminated yellow, and the audible buzzer should sound and be able to be silenced by pressing reset.
- switch off the main switch.
- Uncover both diodes on the motherboard ②
- Switch on at the main switch. ③
- Signal 3 is illuminated yellow, the audible buzzer sounds and cannot be silenced by pressing the reset button. By the requirements of Module 2 suction should now not be possible.
- Switch off at main switch.
- Connect centrifuge plug SV2 back into the socket in the motherboard.
- Replace Module 2.
- Undertake the routine operating test as described in Chapter 20.



Each annual inspection must be recorded in the apparatus logbook!

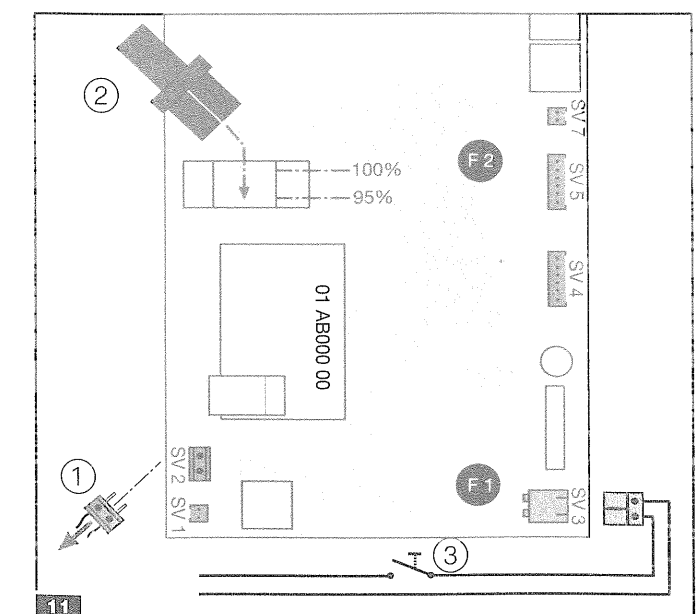
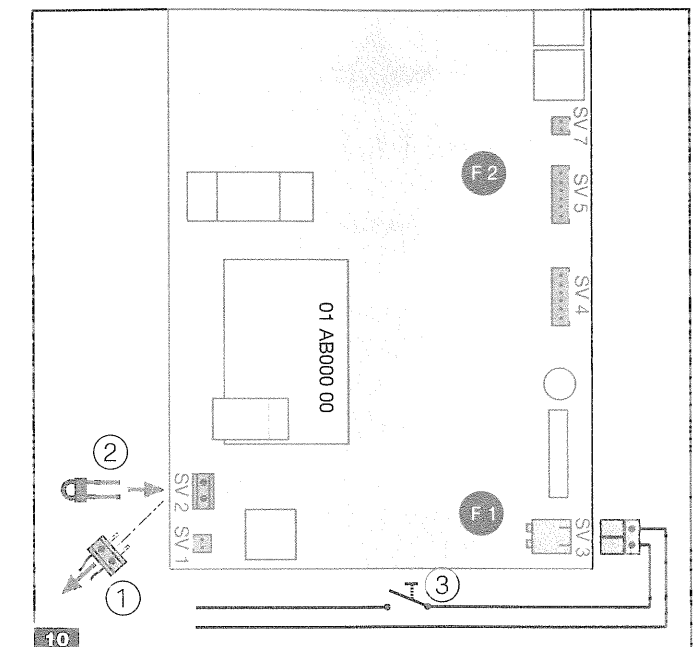
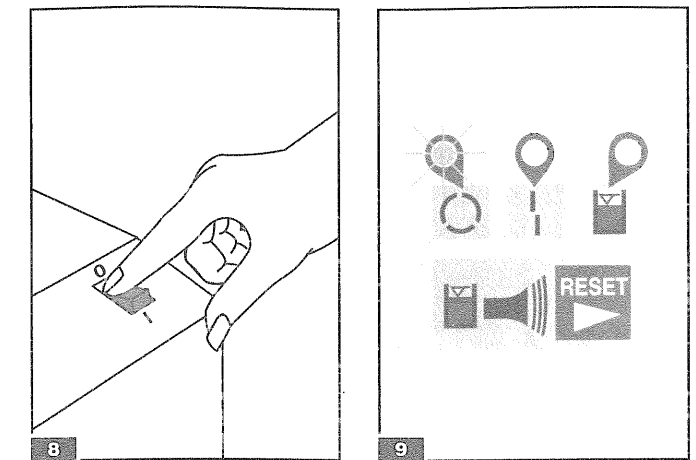

5 yearly inspection

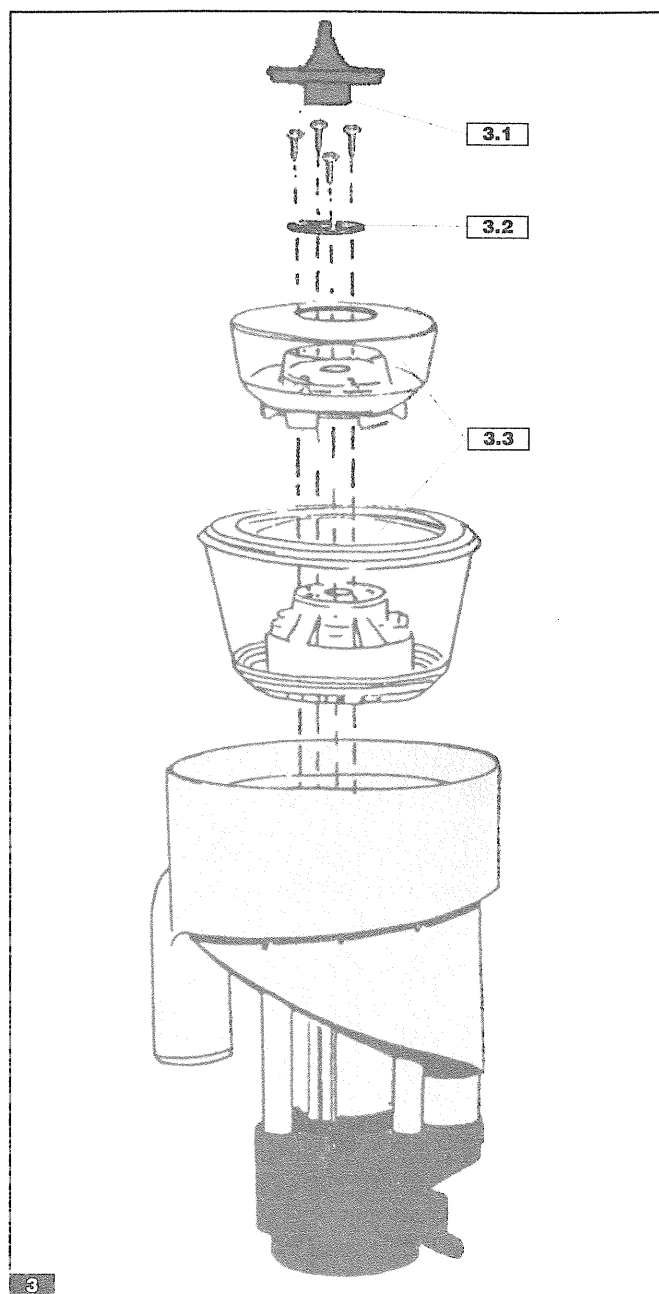
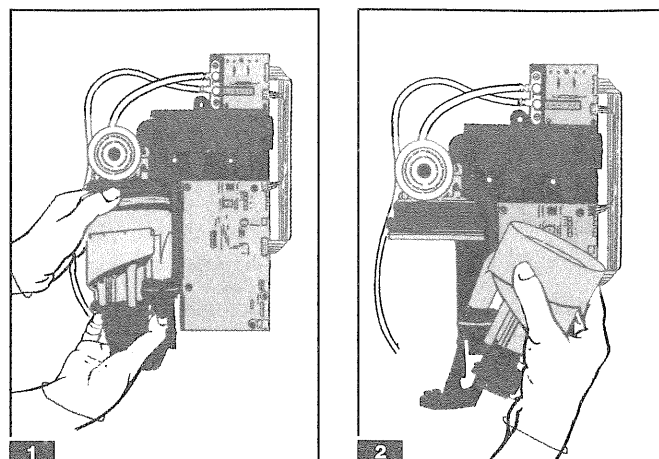

19. 5 yearly inspection:

i In accordance with German waste management regulations, amalgam separators must be at intervals of no longer than 5 years.

- Carry out the annual inspection as described in Chapter 18.
- Check the amalgam separator is correctly mounted and connected.
- Rinse both the basin and suction hose with one litre of clean water and an appropriate disinfectant.

3 Visual control of the Centrifuge:

! Wear protective gloves!
Switch off at the main switch!

- Remove Module 2
- Remove the centrifuge housing clips.
- Pull the centrifuge housing downwards.
- **1** Remove the centrifuge lid (but not the transparent inner seal)
- **2** Swing the centrifuge outwards.
- Remove the centrifuge cap **3.1**
- Loosen the four fixing screws on the centrifuge flange **3.2** and remove the flange.
- Remove the enclosed chambers upwards from the centrifuge **3.3**
- Separate the inner and outer centrifuge chambers from each other.
- Hold each chamber separately up to a light beam and check visually for any soiling, paying special attention to the probe openings on the floor of the chambers.

Blocked or heavily soiled centrifuge chambers should be replaced immediately.

- The centrifuge should be assembled by following the above procedure in reverse.

i Pay special attention to the fixing pins and holes of the chambers!

- - Undertake the routine inspection as described in Chapter 20.

i The 5 year inspections must always be recorded in the equipment logbook!

Routine inspection

20. Routine inspection:

i Undertaking the routine inspection is the easiest way to check the serviceability of the amalgam separator and should be undertaken after every repair or maintenance procedure.

- Switch on the main switch
- ➔ **4** Signal 1 on the external visual display should be lit green.
- ➔ The centrifuge should run twice for a short time before stopping abruptly.

➤ Suction hose free

- ➔ **5** Signal 1 (support signal) and signal 2 (magnetic valve) should be illuminated on the internal visual display and suction power should be available.

➤ Rapid water suction until suction power cuts out.

This proves that when there is more water in the collection container than the pump can cope with (minimum 1.5 litre/min) the security probe is activated and suction power is cut immediately.

- ➔ **6** see diagram
- ➔ **6.1** On the internal visual display both signal 1 (support signal) and signal 3 (pump, Module 2) are illuminated, however signal 3 (magnetic valve) is not. This is because the valve is closed and therefore suction power is broken.

➔ Within 2-3 seconds the solenoid valve reopens and suction power should be available.

- ➔ **6.2** On the internal visual display all signals are on.

➔ After approximately 15 seconds the centrifuge and pump should switch on.

- ➔ **6.3** On the internal visual display only signals 1 and 2 should now be illuminated.

➔ After a short reset phase the centrifuge should begin to run again for a period of approximately 5 seconds pumping the waste and some backwater into the collection container.

➤ Suction pipe fitting

- ➔ **7** No signal is illuminated on the internal visual display.

➤ Rinsing the rinsing basin

- ➔ **8** see diagram
- ➔ **8.1** Only signal 4 should be illuminated on the internal visual display.

The centrifuge runs for as long as the rinsing basin is in operation, then stops abruptly before starting up once again for a short pumping cycle.

- ➔ **8.2** No signal should be illuminated on the internal visual display

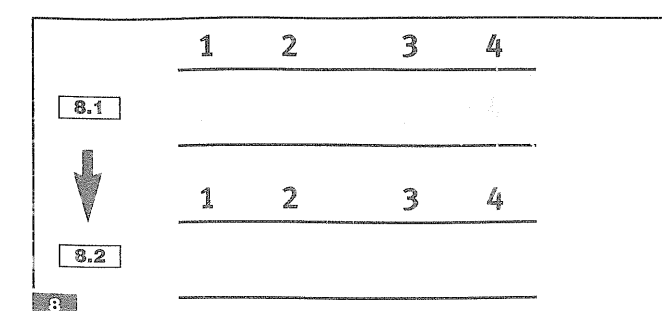
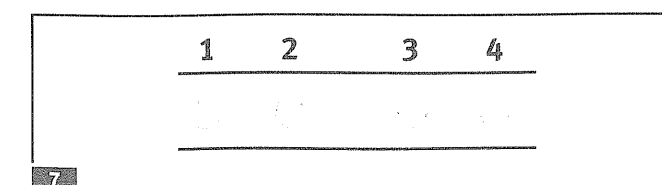
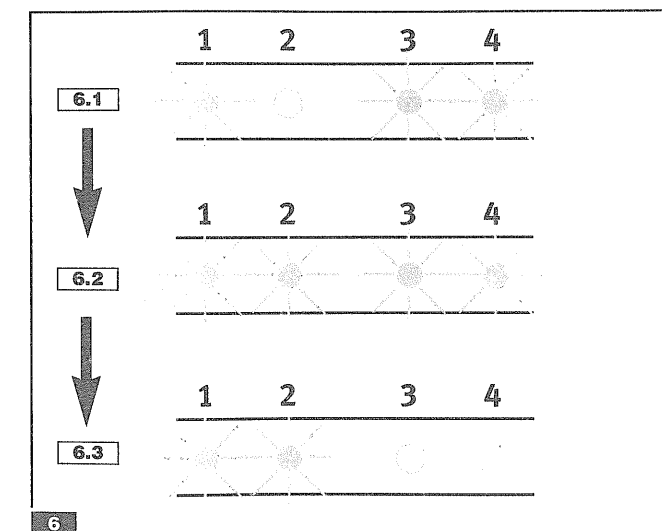
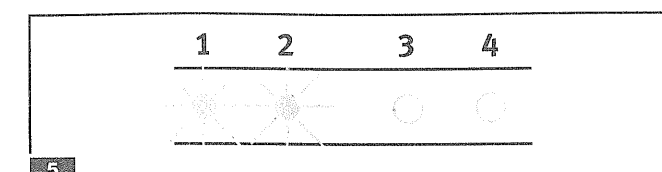
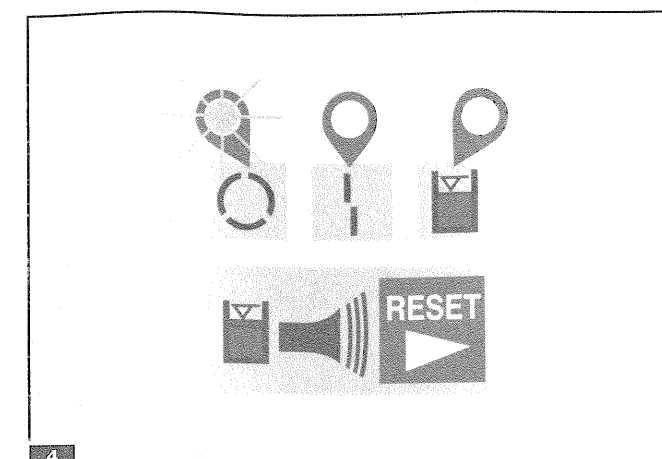

METASYS



Austria

METASYS

Medizintechnik GmbH
Florianistraße 3
A-6063 Rum bei Innsbruck
☎ ++43 / (0) 512 / 20 54 20-0
☎ ++43 / (0) 512 / 20 54 20-7

Germany

METASYS

Medizintechnik GmbH
Ahornstraße 19
D-85614 Kirchseeon
☎ ++49 / (0) 89 / 613874-0
☎ ++49 / (0) 89 / 6135829

France

METASYS France S.a.r.l.

9, bd E. Michelet
F-69008 Lyon
☎ ++33 / (0) 4 / 37 90 22 15
☎ ++33 / (0) 4 / 37 90 22 47
e-mail: info@metasys.fr
<http://www.metasys.fr>

email: info@metasys.com

<http://www.metasys.com>

Italy

DENTAL  SERVICE

METASYS GROUP

Dental Eco Service Italia S.r.l.
Via Torricelli 47
I-37136 Verona
☎ +39/045/981/4477 · ☎ 4475

Ihr METASYS Berater:/Your METASYS agent: